

FORMOSAT-9B Science Payload to Spacecraft Interface Requirement Document

This document contains proprietary and controlled information of Taiwan Space Agency (TASA) in Taiwan and shall not be duplicated in whole or in part for any purpose without permission from TASA.

Taiwan Space Agency
國家太空中心

 TASA 國家太空中心 Taiwan Space Agency	FORMOSAT-9B Science Payload to Spacecraft Interface Requirement Document	FS9B-IRD-XXXX
		01
		2026/05/26
		2 OF 35

Revision/Change Record
改版/變更記錄

Revision 版次	Author 作者	Authorization Date 核可日期	Revision / Change Description 改版/變更說明	Pages Affected 影響頁次
01	張簡仲勛		Initial Issue	All

	FORMOSAT-9B Science Payload to Spacecraft Interface Requirement Document	FS9B-IRD-XXXX
		01
		2026/05/26
		3 OF 35

Table of Content

1	Introduction.....	5
1.1	Purpose	5
1.2	Scope	5
2	References.....	5
2.1	Applicable Documents	5
2.2	Reference Documents.....	5
3	System Requirements	6
3.1	Configuration.....	6
3.2	Operation Modes	6
3.3	Operation Requirements	6
3.4	Mission Life.....	6
3.5	Orbit.....	6
4	Mechanical Interface Requirement.....	7
4.1	Location.....	7
4.2	Mass.....	8
4.3	Centre of Gravity	8
4.4	Field of View	8
4.5	Deployment	9
4.6	Alignment	9
4.7	Mounting	9
4.8	Magnetic Cleanliness.....	9
4.9	Attitude Control.....	9
4.9.1	Pointing Accuracy	9
4.9.2	Pointing Knowledge	9
4.9.3	Positioning Knowledge	9
4.9.4	Operation of Science Payload.....	9
5	Electrical Interface Requirement	10
5.1	Orbit Average Power	10
5.2	Input Voltage.....	10
5.3	Peak Power	10
5.4	Electrical Power Interface	10
5.5	Command and Telemetry Interface	11
5.6	Time Synchronization Interface	12
5.7	Science Data	13
5.7.1	Science Data Interface.....	13
5.7.2	Data Storage	13
5.7.3	Format of Science Data Packet.....	13
5.8	Connector	14
5.9	Grounding.....	14
6	Thermal Interface Requirement.....	15
6.1	Thermal Control	15
6.2	Thermal Power Dissipation	15
7	Operational Interface Requirement (SOCS/SDC).....	16
7.1	Science Payload Mission Timeline (MTL).....	16

	FORMOSAT-9B Science Payload to Spacecraft Interface Requirement Document	FS9B-IRD-XXXX
		01
		2026/05/26
		4 OF 35

7.2	Science P/L Command Procedure	18
7.3	Science P/L Acquisition Schedule Report (ASR).....	19
7.4	NORAD 2-Line Element	21
7.5	Science P/L SOH Data.....	24
7.6	Science Data	24
8	Environment Interface Requirements	25
8.1	Sine Vibration	25
8.2	Random Vibration.....	25
8.3	Shock	26
8.4	Thermal Test(s).....	26
9	Requirements Verification.....	27
9.1	Requirements Verification Cross-Reference Matrix (VCRM)	28
Appendix A. Acronym.....		29
Appendix B. Sample Science Payload ICD Verification Cross- Reference Matrix (VCRM)35		

	FORMOSAT-9B Science Payload to Spacecraft Interface Requirement Document	FS9B-IRD-XXXX
		01
		2026/05/26
		5 OF 35

1 Introduction

1.1 Purpose

This document defines the interface requirements between FORMOSAT-9B spacecraft bus and science payload.

1.2 Scope

This document contains the interface requirements for procurement of science payload for the FORMOSAT-9 program, specifically confined to FS-9B mission.

2 References

2.1 Applicable Documents

In this section are defined those documents which are applicable associated to the present document. If the issue of document is not listed, the last issue is applicable.

AD1 FS9B-SPEC-XXXX FORMOSAT-9B Component Environmental Specification

2.2 Reference Documents

RD1 FS9B-ICD-XXXX FORMOSAT-9B Science Payload to Spacecraft ICD

	FORMOSAT-9B Science Payload to Spacecraft Interface Requirement Document	FS9B-IRD-XXXX
		01
		2026/05/26
		6 OF 35

3 System Requirements

3.1 Configuration

All communication and power lines to science payload (SPL) shall go through the on-board computer (OBC) and Power Control Unit (PCU). The PCU will provide all electric power to the SPL, and the OBC will provide necessary command and telemetry interfaces to the SPL. Harnesses between the spacecraft bus to the SPL will be provided by TASA, any SPL internal harness shall be provided by the contractor.

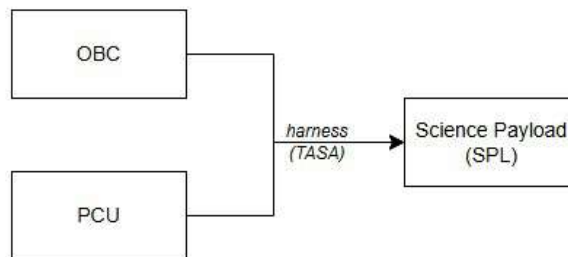

Figure 3.1-1: Science payload configuration

3.2 Operation Modes

Operation modes shall be POWER ON and POWER OFF. The science payload shall operate autonomously in normal operation.

3.3 Operation Requirements

The science payload shall be POWER OFF when it is not operated. The operation of science payload shall always not interfere with the mission payload operation.

3.4 Mission Life

The mission life of science payload for FS-9B shall be at least 3 years in orbit subsequent to 3 years of ground testing and storage.

3.5 Orbit

The FORMOSAT-9B mission orbit is at 514 km altitude with inclination 97.45 degree as a sun-synchronous orbit. The local time of descending node is set at 10:00 AM – 11:00 AM.

4 Mechanical Interface Requirement

The footprint of the SPL shall be specified in the Science Payload to Spacecraft Interface Control Document (ICD).

4.1 Location

Two location options with respected dimension constraints for the SPL are shown below in Figure 4.1-1. The SPL shall select only **one** option for the design.

Position	1	2
Location	+X-Y (lower)	+X-Y (upper)
Size (cm)	$\leq 10(L) \times 20(W) \times 10(H)$ [TBD]	$\leq 20(L) \times 20(W) \times 10(H)$ [TBD]

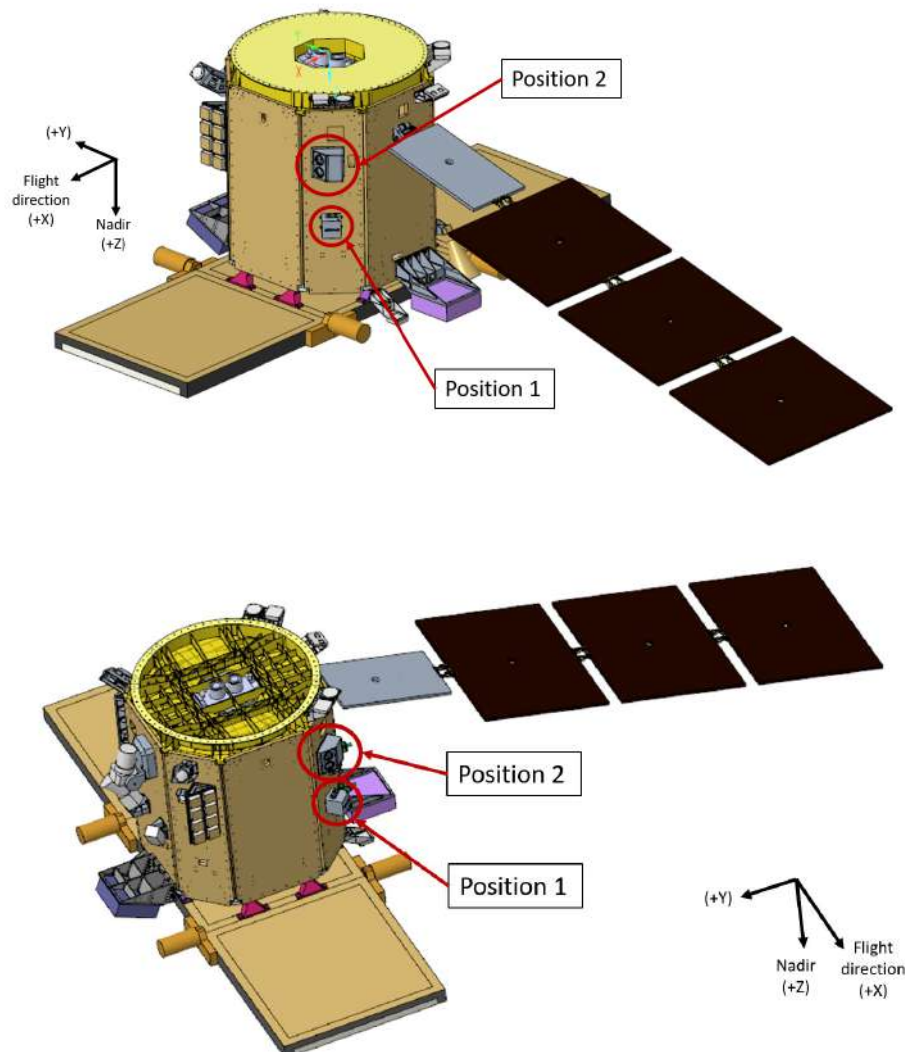

Figure 4.1-1 Science payload location in position 1 and 2

	FORMOSAT-9B Science Payload to Spacecraft Interface Requirement Document	FS9B-IRD-XXXX
		01
		2026/05/26
		8 OF 35

4.2 Mass

The SPL, including any necessary hardware, shall be less than 5kg.

4.3 Centre of Gravity

The center of gravity of the SPL shall be within 5% of the geometric center of the envelope.

4.4 Field of View

The field of view of both locations for the SPL are set to be $\pm 30^\circ$ [TBD] as shown below in Figure 4.4-1 and Figure 4.4-2 for two locations respectively.

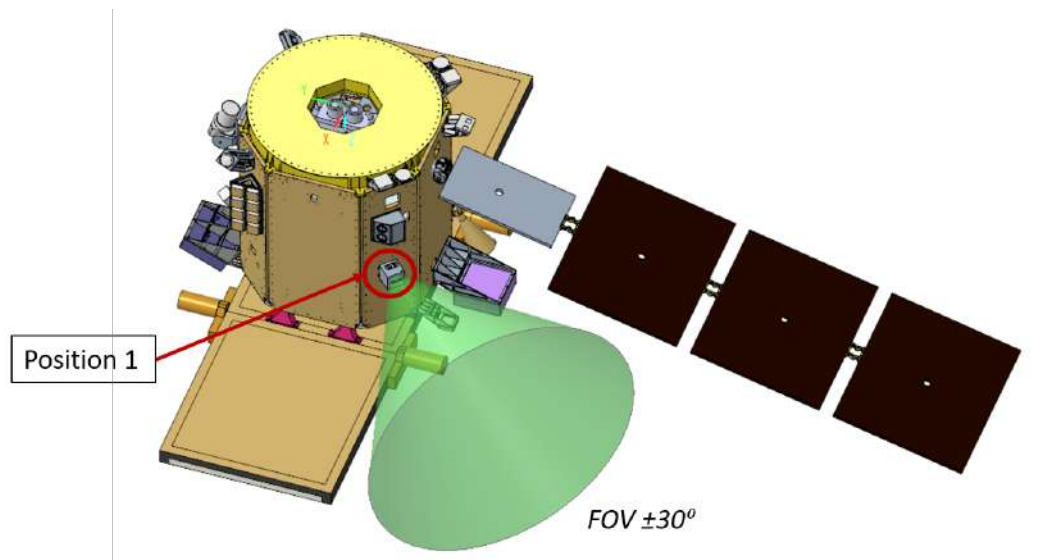

Figure 4.4-1 Field of View of SPL in position 1

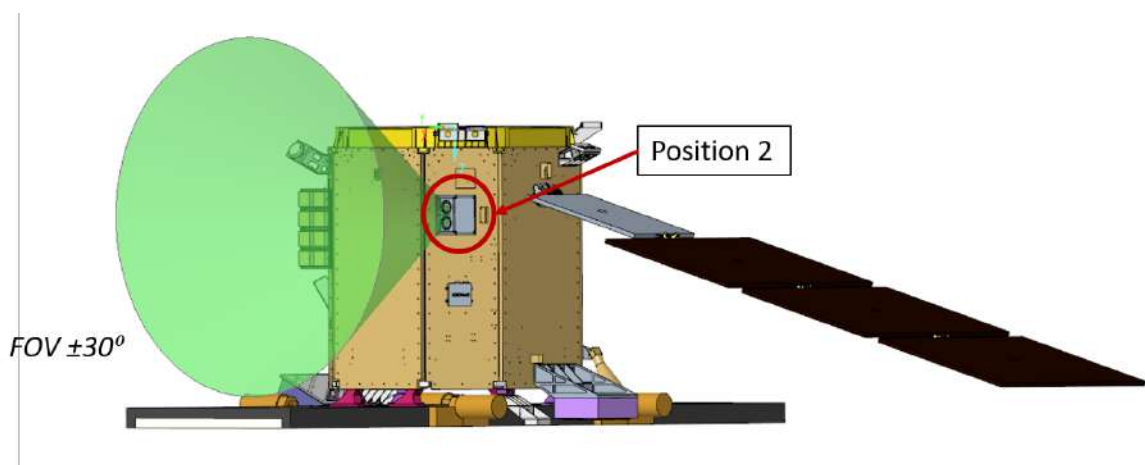

Figure 4.4-2 Field of View of SPL in position 2

	FORMOSAT-9B Science Payload to Spacecraft Interface Requirement Document	FS9B-IRD-XXXX
		01
		2026/05/26
		9 OF 35

4.5 Deployment

No deployment mechanism in any form shall be allowed in the SPL.

4.6 Alignment

If alignment is necessary, alignment cube shall be included on the SPL design.

4.7 Mounting

The SPL shall have a flat mounting surface that conducts electrically and thermally to the spacecraft bus.

4.8 Magnetic Cleanliness

Wherever possible, non-magnetic material shall be used and the utilization of permanent magnets shall be avoided.

4.9 Attitude Control

4.9.1 Pointing Accuracy

The spacecraft bus will maintain the pointing accuracy less than 0.03 degree in pitch, roll and yaw axes. All values are 3σ .

4.9.2 Pointing Knowledge

The spacecraft bus will maintain the pointing knowledge less than 0.02 degree in pitch, roll and yaw axes. All values are 3σ .

4.9.3 Positioning Knowledge

The spacecraft bus will provide on-board position knowledge better than 25m (3σ) for each axis.

4.9.4 Operation of Science Payload

The nominal attitude of satellite is LVLH (local-vertical-local-horizontal). The operation of the SPL shall not interfere with SAR imaging and regular satellite normal operation. The science payload shall coordinate with TASA for science payload mission operation planning.

 TASA 國家太空中心 Taiwan Space Agency	FORMOSAT-9B Science Payload to Spacecraft Interface Requirement Document	FS9B-IRD-XXXX
		01
		2026/05/26
		10 OF 35

5 Electrical Interface Requirement

5.1 Orbit Average Power

The science payload shall consume less than 12W [TBD] orbit average power.

5.2 Input Voltage

The spacecraft bus will provide DC input voltage for 28±6 Vdc.

5.3 Peak Power

The science payload peak power shall not exceed 20W. Spacecraft will cut off power supply to science payload if over-current protection is triggered.

5.4 Electrical Power Interface

The power interface between spacecraft and science payload includes +28V power and an over-current flag. Science payload shall implement the over-current detection mechanism to shut down itself and report to spacecraft when it occurs.

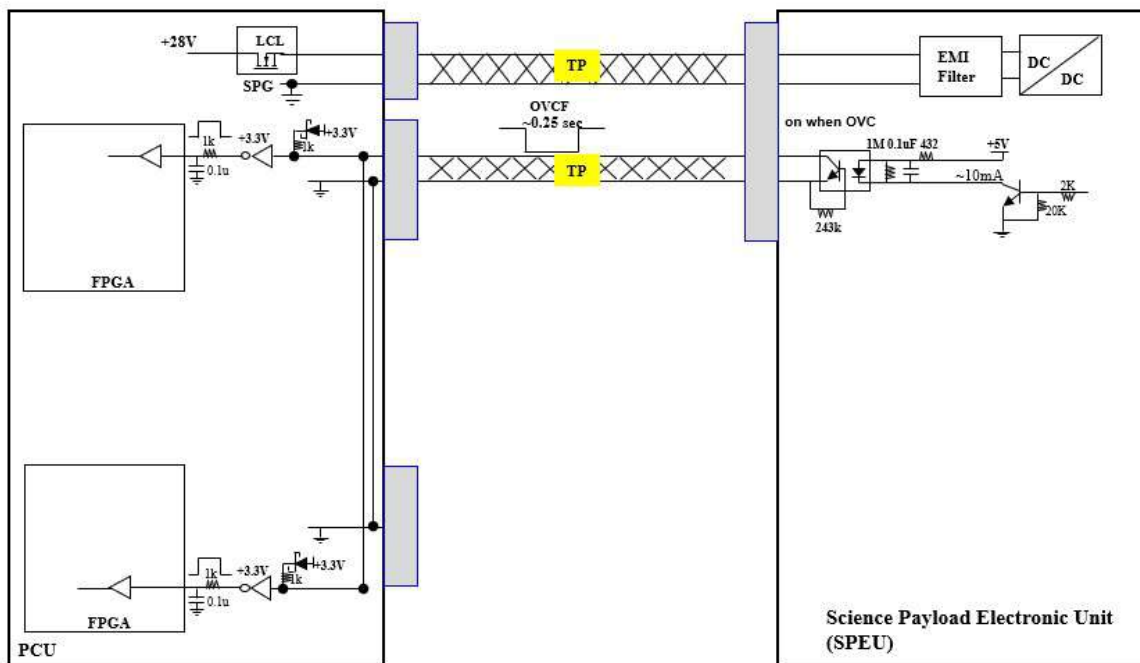

Figure 5.4-1 Electric Power Interface

5.5 Command and Telemetry Interface

The spacecraft bus will provide two UART interfaces to science payload command and telemetry. The interface shall be RS422 UART and the baud rate shall be operated at 115.2 kbps. Science payload shall provide two redundant RS422/UART interfaces for command and telemetry.

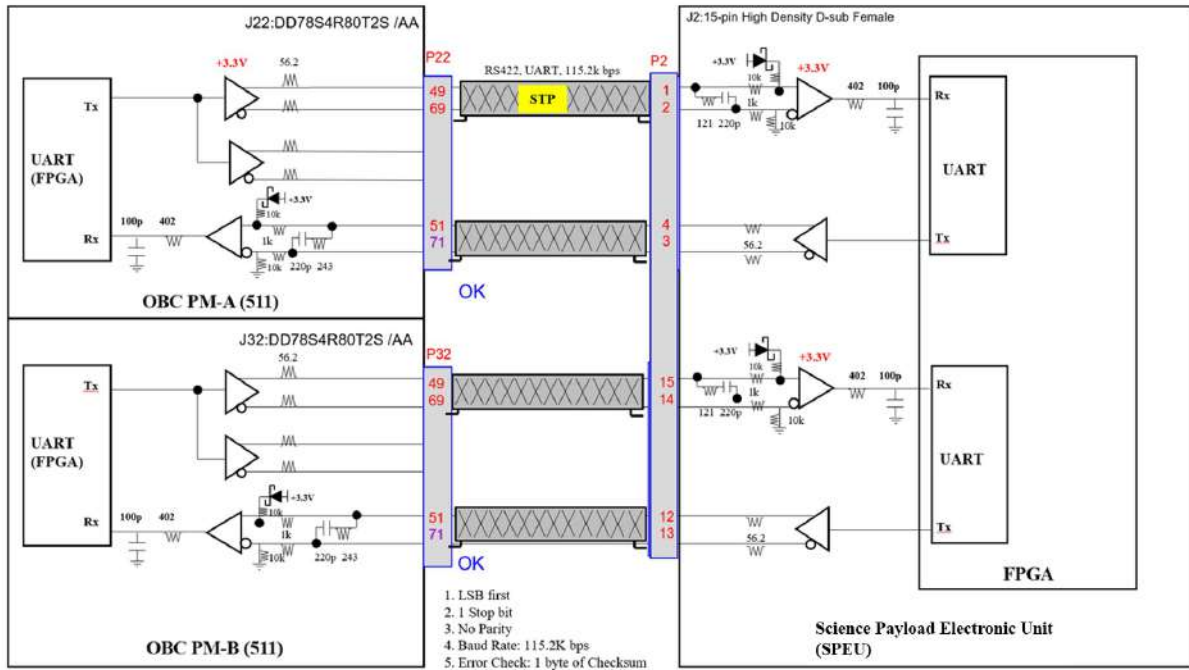

Figure 5.5-1 Command and Telemetry Interface

5.6 Time Synchronization Interface

Science payload shall provide two redundant PPS interfaces in RS422 signal for time synchronization. Science payload shall provide two interface circuits as shown in Figure 3.5-2 for PPS interface. Detail interface will be specified in the “Science Payload to Spacecraft Interface Control Document”.

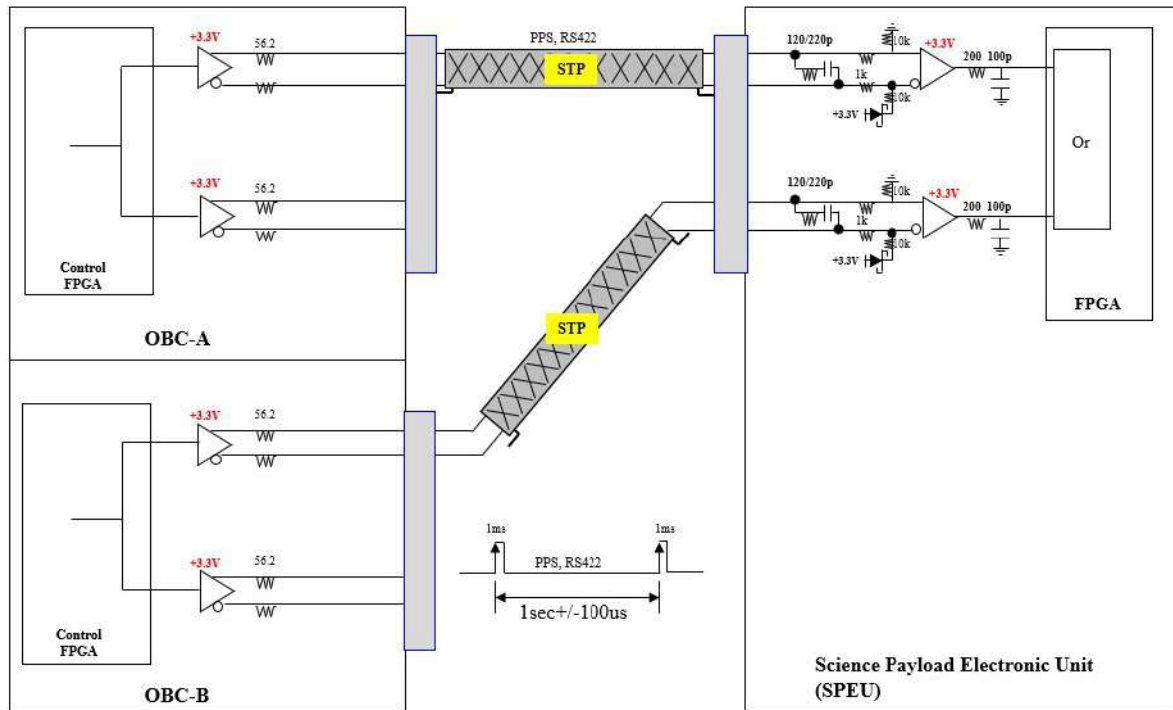

Figure 5.6-1 PPS Signal Interface

5.7 Science Data

5.7.1 Science Data Interface

Science payload shall provide two redundant SpaceWire interface for data link. The data link rate shall be operated in 10Mbps. Science payload shall provide two sets of interface circuits as shown in Figure 3.7-1 for science data.

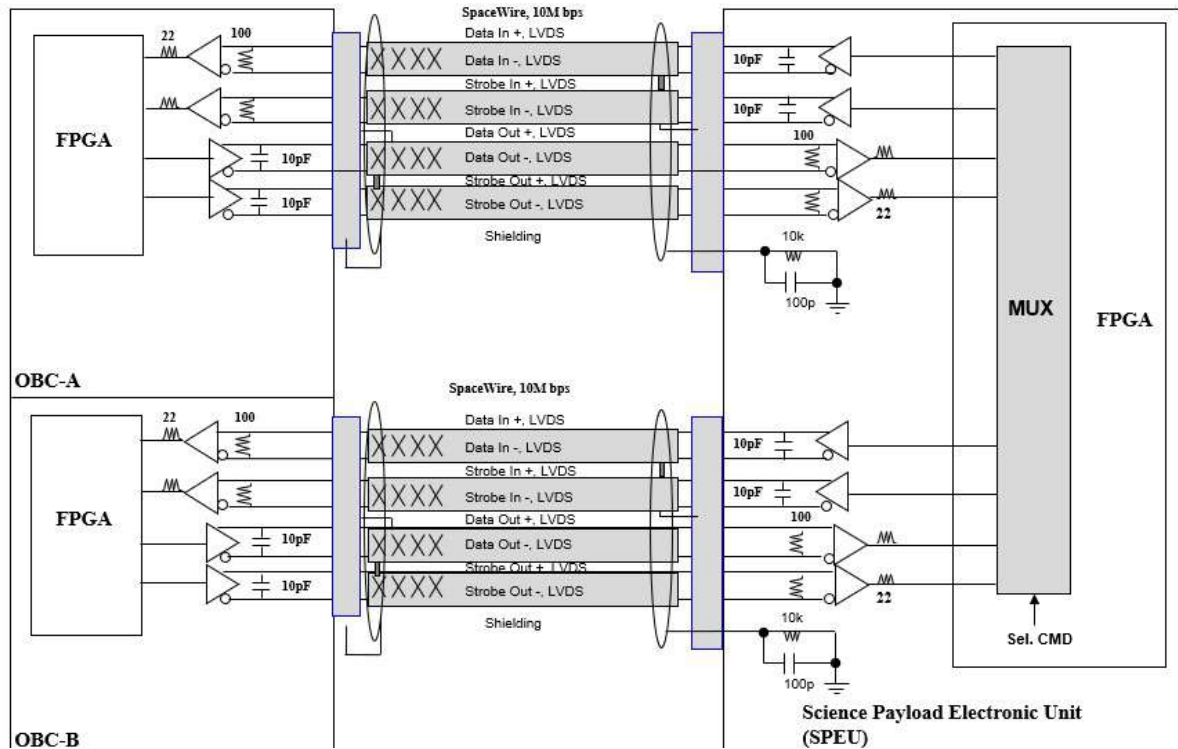

Figure 5.7-1 Science Data Interface

5.7.2 Data Storage

The spacecraft bus will provide data storage capacity for science data excluding EDAC data from science payload up to 2 Gbits per day.

5.7.3 Format of Science Data Packet

The format of the science data packet will be specified in the “Science Payload to Spacecraft Interface Control Document”.

5.8 Connector

The interface connector shall use D-SUB connector for power, command and telemetry interface, and use micro-D connector for SpaceWire data interface as shown in the tables below.

J03	(9S Micro D-type)
1	SPL_A_SPW_DIN+
2	SPL_A_SPW_SIN+
3	Inner shield
4	SPL_A_SPW_SOUT-
5	SPL_A_SPW_DOUT-
6	SPL_A_SPW_DIN-
7	SPL_A_SPW_SIN-
8	SPL_A_SPW_SOUT+
9	SPL_B_SPW_DOUT+

J04	(9S Micro D-type)
1	SPL_B_SPW_DIN+
2	SPL_B_SPW_SIN+
3	Inner shield
4	SPL_B_SPW_SOUT-
5	SPL_B_SPW_DOUT-
6	SPL_B_SPW_DIN-
7	SPL_B_SPW_SIN-
8	SPL_B_SPW_SOUT+
9	SPL_B_SPW_DOUT+

5.9 Grounding

The SPL shall be grounded in accordance with the spacecraft bus grounding scheme as specified in AD1.

	FORMOSAT-9B Science Payload to Spacecraft Interface Requirement Document	FS9B-IRD-XXXX
		01
		2026/05/26
		15 OF 35

6 Thermal Interface Requirement

6.1 Thermal Control

The science payload shall provide thermal control by itself if necessary. Any necessary heater or thermal monitor devices for science payload operation and non-operation stage shall be provided by science payload.

6.2 Thermal Power Dissipation

The science payload can be thermally conductively to spacecraft bus structure to dissipate thermal power if necessary.

7 Operational Interface Requirement (SOCS/SDC)

The SOCS supports the TASA FORMOSAT-series satellite missions. The SDC interacts with SOCS and the SDC science team to plan and perform the science operations. The SDC is responsible for the science payload operation support, science data management, processing, analyzing and archiving. The SDC is also responsible for distributing the data and algorithms. Furthermore, the SDC will actively communicate with research and education communities to promote maximum usage of the science data. Figure 3.11-1 shows the data interface between SDC and SOCS.

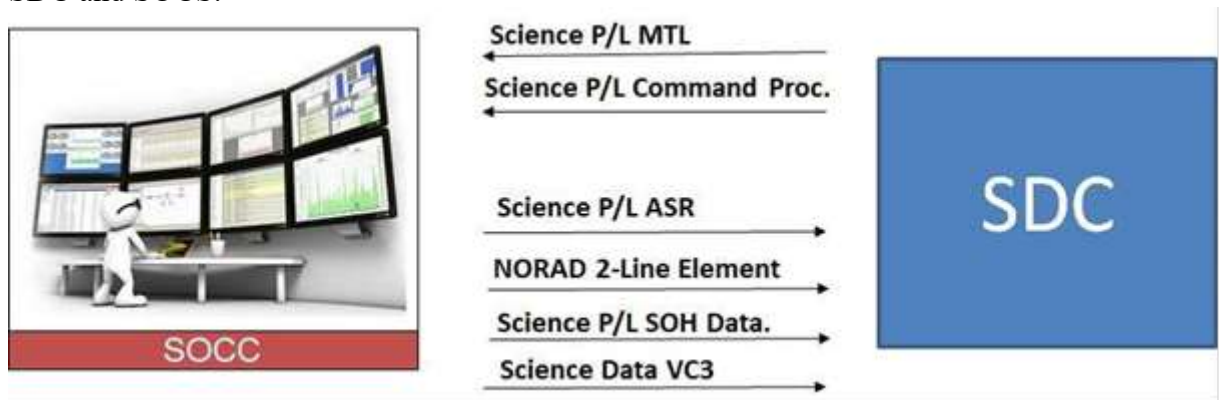

Figure 3.11-1 Data interface between SOCS and SDC

The following presented mission timeline are examples from the **FS-9A mission**

7.1 Science Payload Mission Timeline (MTL)

Purpose/Description	The Mission Timeline contains sequence of on-board events regarding desired activities, including command procedure.
Originator	SDC
Destination	SOCS
Frequency/Volume	One to five times per week (TBR) / Variable data volume
File name/E-mail Subject Convention	FS9A_SDC_yyyymmdd_timeline.txt (yyyy: 4 digits of year, mm: months, dd: days) Date of file name represents the date to perform measurement. For example: FS9A_SDC_20191214_timeline.txt
Data Link Interface	Internet
Transport Interface	TCP/IP SFTP
Comments	

	FORMOSAT-9B Science Payload to Spacecraft Interface Requirement Document	FS9B-IRD-XXXX
		01
		2026/05/26
		17 OF 35

All fields are left adjusted.

Line Number	Type/Size	Field Name	Contents/Format and Unit/Range of Values
1	string/8 bytes	LABEL_1	“SOURCE: “
1	string/variable	SOURCE	Author of File / “FS9A SDC”
2	string/13 bytes	LABEL_2	“DESTINATION: “
2	string/variable	DESTINATION	Destination of File / “SOCS”
3	string/11 bytes	LABEL_3	“FILE NAME: “
3	string/variable	FILE_NAME	file name / “FS9A_SDC 20191214 timeline.txt”
4	string/11 bytes	LABEL_4	“DATE TIME: “
4	string/19 bytes	DATE_TIME	Time to generate this file in the format of “yyyy/mm/dd hh:mm:ss”
5	string/12 bytes	LABEL_5	“SPACECRAFT: “
5	string/variable	SPACECRAFT	Satellite ID / “FS9A”
6	string/12 bytes	LABEL_6	“INSTRUMENT: “
6	string/variable	INSTRUMENT	Instrument ID / “SDC”
7	string/16 bytes	LABEL_7	“REQUEST_WINDOW: “
7	string/variable	REQUEST_WINDOW	“yyyy/ddd 00:00:00– yyyy/ddd 00:00:00”
8	string/5 bytes	LABEL_8	“EVENT”/leading label of EVENT column
8	string/3 bytes	LABEL_9	“UTC” / leading label of UTC column
8	string/9 bytes	LABEL_15	“Procedure” / leading label of Proced column for Command Procedure
9	string/2 byte	Event	The number of the requested event count
9	string/17 bytes	UTC	UTC time when the activity commences, in “yyyy/ddd hh:mm:ss” format / year, day, hour, minute, second / 2000:2050, 001:365, 00:23, 00:59, 00:59

Line Number	Type/Size	Field Name	Contents/Format and Unit/Range of Values
9	string/19 bytes	Procedure	The name of the Command procedure “SDC_PROCYydddFn.prc” yy:year, ddd:day of year, n:the nth command procedure of the same day or “NA”
10	same as line 9	Same as line 9	Same as line 9

 TASA 國家太空中心 Taiwan Space Agency	FORMOSAT-9B Science Payload to Spacecraft Interface Requirement Document	FS9B-IRD-XXXX
		01
		2026/05/26
		18 OF 35

11	same as line 9	Same as line 9	Same as line 9
Last	string/13 bytes	LABEL_16	“END OF REQUEST”

```

SOURCE: FS9A_SDC
DESTINATION: SOCC
FILE NAME: FS9A_SDC_2025275_timeline.txt
DATE TIME: 2024/02/19 03:26:27
SPACECRAFT: FS9A
INSTRUMENT: SDC
#
REQUEST_WINDOW: 2025/275 00:00:00 - 2025/276 00:00:00
#ACTIVITY
Event          UTC      Procedure
1 2025/275 12:12:35 10      FS9A_SPL_PROC2025_275F1.prc

END OF REQUEST

```

7.2 Science P/L Command Procedure

	Science Payload Command Procedures
Purpose/Description	This file contains command mnemonics and the arguments and the time tag corresponded to the command procedure activity requested in the Science Payload Mission Timeline.
Originator	SDC
Destination	SOCS MCC
Frequency/Volume	variable / variable data volume
File name/E-mail Subject Convention	FS9A_SDC_PROCyydddFn.prc (SDC: instrument name, yy: last 2 digits of year, ddd: day of year, n: the nth Command Procedure of the same day. For example: FS9A_SDC_PROC19348F1.prc
Data Link Interface	Internet
Transport Interface	TCP/IP SFTP
Comments	1. The content of the Command Procedure will follow the XPSOC command format beginning with relative time tag “CMD” in each line.

	FORMOSAT-9B Science Payload to Spacecraft Interface Requirement Document	FS9B-IRD-XXXX
		01
		2026/05/26
		19 OF 35

```

00:01:05.000- # Select
00:00:00.000^ CMD P SELPWR "A" SRC=TTQ

00:01:00.000- # Power up on
00:00:00.000^ CMD C ESWION SRC=TTQ

00:00:55.000- # Delete file0 if existed, before Start record 30 sec
00:00:00.000^ CMD DCDSFILEDEL FILE_NAME = 'File_0' SRC=TTQ

00:00:40.000- # Create file [file0], before Start record 15 sec
00:00:00.000^ CMD DCDSFILECRE FILE_CAPACITY = 4 FILE_DEVICE = 'SPL_1' FILE_NAME = 'File_0' FILE_TYPE = 'Linear' SRC=TTQ

00:00:25.000- # Start record [file0]
00:00:00.000^ CMD DCDSSTARTREC FILE_NAME = 'File_0' SRC=TTQ

00:00:15.000- # Sensor on
00:00:00.000^ CMD S SENSON SRC=MPQ

00:00:10.000- # IDMIT mode
00:00:00.000^ CMD S IDMIT SRC=MPQ

00:00:05.000- # switch to [safe mode]
00:00:00.000^ CMD S SAFE SRC=MPQ

00:00:00.000 # switch to [fast mode]

```

7.3 Science P/L Acquisition Schedule Report (ASR)

Science Payload Acquisition Schedule Report	
Purpose/Description	This file contains conflict-free activities including on-board events and ground events.
Originator	SOCS
Destination	SDC
Frequency/Volume	Once per day / Variable data volume
File name/E-mail Subject Convention	FS9A_SDC_yyyymmdd.sch (yyyy: 4 digits of year, mm: months, dd: days) For example: FS9A_SDC_20191214.txt
Data Link Interface	Internet
Transport Interface	TCP/IP SFTP
Comments	

All fields are left adjusted.

Line Number	Type/Size	Field Name	Contents/Format and Unit/Range of Values
1	string/8 bytes	LABEL_1	“SOURCE: “
1	string/variable	SOURCE	Author of File: “SOCS”

This document contains proprietary and controlled information of Taiwan Space Agency (TASA) in Taiwan and shall not be duplicated in whole or in part for any purpose without permission from TASA.

 TASA 國家太空中心 Taiwan Space Agency	FORMOSAT-9B Science Payload to Spacecraft Interface Requirement Document	FS9B-IRD-XXXX
		01
		2026/05/26
		20 OF 35

2	string/13 bytes	LABEL_2	“DESTINATION: “
2	string/variable	DESTINATION	Destination of File: “SDC”
3	string/11 bytes	LABEL_3	“FILE NAME: “
3	string/variable	FILE_NAME	file name / “FS9A_SDC_20191214.sch”
4	string/11 bytes	LABEL_4	“DATE TIME: “
4	string/19 bytes	DATE_TIME	Time to generate this file in the format of “yyyy/mm/dd hh:mm:ss”
5	string/12 bytes	LABEL_5	“SPACECRAFT: “
5	string/variable	SPACECRAFT	Satellite ID / “FS9A”
6	string/12 bytes	LABEL_6	“INSTRUMENT: “
6	string/variable	INSTRUMENT	Instrument ID / “SDC”
7	string/19 bytes	LABEL_7	“UTC” / leading label of UTC column
7	string/23 bytes	LABEL_13	“Procedure” / leading label of Procedure column
8	string/19 bytes	UTC	UTC time when the event commences, in “yyyy/ddd hh:mm:ss” format / year, day, hour, minute, second / 2000:2100, 001:365, 00:23, 00:59, 00:59
8	string/19 bytes	Procedure	The name of the command procedure “SDC_PROCYyddFn.prc” yy: year, ddd: day of year, n: the nth command procedure of the same day.
9	Same as line 8	Same as line 8	Same as line 8
10	Same as line 8	Same as line 8	Same as line 8
	“	“	“
11	string/22 bytes	LABEL_14	“Unscheduled Request”
12	string/25 bytes	LABEL_15	“Activity” / leading label of Activity column
12	string/19 bytes	LABEL_16	“UTC” / leading label of UTC column
12	string/9 bytes	LABEL_17	“Error_MSG” / leading label of Error_MSG column
13	string/25 bytes	Activity	“SDC_PROCYyddFn.prc”
13	string/19 bytes	UTC	UTC time when the activity should commence, in “yyyy/ddd hh:mm:ss” format / year, day, hour, minute, second / 2000:2050, 001:366, 00:23, 00:59, 00:59
13	string/variable	Error_MSG	The reason of the request not being scheduled
14	Same as line 13	Same as line 13	Same as line 13

	FORMOSAT-9B Science Payload to Spacecraft Interface Requirement Document	FS9B-IRD-XXXX
		01
		2026/05/26
		21 OF 35

14	Same as line 13	Same as line 13	Same as line 13
Last	String/13 bytes	LABEL_18	“END OF REPORT”

```

SOURCE: SOCC
DESTINATION: FS9A SDC
FILE NAME: FS9A_SDC_2025275.sch
DATE TIME: 2024/02/19 03:26:27
SPACECRAFT: FS9A
INSTRUMENT: SDC
#
Event          UTC          Procedure
1              2025/275 12:12:35  FS9A_SPL_PROC2025_275F1.prc
Unscheduled Request:
Activity       UTC          Error_MSG
END OF REQUEST

```

7.4 NORAD 2-Line Element

	NORAD 2-Line Element
Purpose/Description	FORMOSAT-9A orbital parameters for SDC to compute the satellite trajectory. It is in the standard NORAD 2-line element format.
Originator	SOCS FDF
Destination	FS9A SDC
Frequency/Volume	Once per 3 days. [TBR] / 160 Bytes
File name/E-mail Subject Convention	SSSS_yyyymmdd_hhmm.nor (SSSS: S/C name in capital, yyyy: 4 digits of year, mm: months, dd: days, hh: hours, mm: minutes) For example: FS9A_20151203_0232.nor
Data Link Interface	Internet
Transport Interface	TCP/IP SFTP
Comments	SOCS as the data server, SDC to retrieve the data via SFTP. SOCS: Gateway-PC, username/passwd: xxx/xxx (TBD)

Lines 1 and 2 are the standard format of Two-Line Orbital Element Set identical to that used by NORAD and NASA. The format description is:

Byte	Field Name	Description
------	------------	-------------

	FORMOSAT-9B Science Payload to Spacecraft Interface Requirement Document	FS9B-IRD-XXXX
		01
		2026/05/26
		22 OF 35

Byte 1	Record Number	Line 1. One integer digit: Always 1
Byte 2	Blank	ASCII Space
Bytes 3-7	Satellite Number	Five integer digits: right justified with possible leading blank character.
Byte 8	Classification	One alphabetical character for classification
Byte 9	Blank	ASCII Space
Byte 10-11	Launch Year	Last two digits of launch year
Bytes 12-14	Launch Number of Year	Three integer digits.
Bytes 15-17	Piece Number	Three alphabetical characters with possible trailing blanks.
Byte 18	Blank	ASCII Space
Bytes 19-20	Epoch Year	Two integer digits: last two digits of y
Bytes 21-32	Epoch Day	xxx.xxxxxxx: Epoch (Julian day and fractional portion of the day-12 digits including decimal point at byte 24).
Byte 33	Blank	ASCII Space
Byte 34	Sign of First Time Derivative of Mean Motion (rev/day ²)	space or -: space = positive, - = negative
Bytes 35-43	Value of First Time Derivative of Mean Motion (rev/day ²)	.xxxxxxx (nine characters including decimal point at byte 35)
Byte 44	Blank	ASCII Space
Byte 45	Sign of Second Time Derivative of Mean Motion (rev/day ³)	space or -: space = positive, - = negative
Bytes 46-52	Value of Second Time Derivative of Mean Motion (rev/day)	(.)xxxxx-x (seven characters; the decimal point is implied)
Byte 53	Blank	ASCII Space
Byte 54	Sign of BSTAR Drag Term (for SPG4 Theory) or Radiation Pressure Coefficient (for SDP4 Theory)	space or -: space = positive, - = negative
Bytes 55-61	Value of BSTAR Drag Term (for SPG4 Theory) or Radiation Pressure Coefficient (for SDP4 Theory)	(.)xxxxx-x (seven characters; the decimal point is implied)
Byte 62	Blank	ASCII Space

Byte	Field Name	Description
------	------------	-------------

This document contains proprietary and controlled information of Taiwan Space Agency (TASA) in Taiwan and shall not be duplicated in whole or in part for any purpose without permission from TASA.

	FORMOSAT-9B Science Payload to Spacecraft Interface Requirement Document	FS9B-IRD-XXXX
		01
		2026/05/26
		23 OF 35

Byte 63	Ephemeris Type	One integer digit: 0 = SGP4 Theory, 3 = SDP4 Theory
Byte 64	Blank	ASCII Space
Bytes 65-68	Element Number	
Byte 69	Check Sum (Modulo 10)	letters, blanks, periods, plus signs=0; minus signs = 1
Bytes 70-80	Blank	ASCII Spaces
Byte 81	Record Number	Line 2. One integer digit: Always 2
Byte 82	Blank	ASCII Space
Bytes 83-87	Satellite Number	Five integer digits: right justified with possible leading blank character.
Byte 88	Blank	ASCII Space
Byte 89-96	Inclination (deg)	xxx.xxxx (eight characters including decimal point at byte 92)
Byte 97	Blank	ASCII Space
Byte 98-105	Right Ascension of Ascending Node (deg)	xxx.xxxx (eight characters including decimal point at byte 101)
Byte 106	Blank	ASCII Space
Byte 107-113	Eccentricity	[.]xxxxxxx (seven characters, the decimal point is implied)
Byte 114	Blank	ASCII Space
Byte 115-122	Argument of Perigee (deg)	xxx.xxxx (eight characters including decimal point at byte 118)
Byte 123	Blank	ASCII Space
Byte 124-131	Mean Anomaly (deg)	xxx.xxxx (eight characters including decimal point at byte 127)
Byte 132	Blank	ASCII Space
Byte 133-143	Mean Motion	xx.xxxxxxxx (eleven characters including decimal point at byte 135)
Byte 144-148	Revolution number at epoch (revs)	
Byte 149	Check Sum (Modulo 10)	
Bytes 150-160	Blank	ASCII Spaces

Example: NORAD 2-Line Element

1	25616U	99002A	00294.12500000	.00000032	00000+0	54508-3	0	3301
2	25616	34.9813	161.1594	0028712	78.5969	203.0919	14.82790364	93742

	FORMOSAT-9B Science Payload to Spacecraft Interface Requirement Document	FS9B-IRD-XXXX
		01
		2026/05/26
		24 OF 35

7.5 Science P/L SOH Data

	Science Payload SOH Data
Purpose/Description	This file contains the SOH telemetry data packets from Command and Telemetry Channel generated by the SDC instruments, and is extracted from XPSOC dump file.
Originator	SOCS SCC
Destination	SDC
Frequency/Volume	Whenever data is available/ variable
File name/E-mail Subject Convention	FS9A_SDC_yyyydddhhmmss_ppp.dmp (yyyy: last 2 digits of year, ddd: day of year, hh: hour, mm: minutes, ss:second, ppp:packet APID) For example: FS9A_SDC_2015302120103_70D.dmp
Data Link Interface	Internet
Transport Interface	TCP/IP SFTP
Comments	SOCS: Gateway-PC, username/passwd: xxx/xxx

7.6 Science Data

	Science Data VC3
Purpose/Description	This file contains the telemetry packets of science data from Science Data Channel as generated by the SDC instruments.
Originator	SOCS SCC
Destination	FS9A SDC
Frequency/Volume	Whenever data is available/ 1.5 Gbits per day
File name/E-mail Subject Convention	FS9A_yyyydddhhmmssxx.vc3 (TBD) (yyyy: digits of year, ddd: day of year, hh: hour, mm: minutes, ss:second, xx:version) For example: FS9A_201512809323101.vc3
Data Link Interface	Internet
Transport Interface	TCP/IP SFTP
Comments	SOCS: Gateway-PC, username/passwd: xxx/xxx (TBD)

FORMOSAT-9A Telemetry is compliant to CCSDS/ECSS standards.

The telemetry emission interface executes the following function:

The Header Packets and Data Packets identified by different APID have been grouped and sorted by the generation time shown in the secondary header. The packets are in sequential order and are separated into a single file by a Header Packet and its following data packets.

Default allocation of the Virtual Channel is done according to the data source of the telemetry frames:

Virtual Channel 0 for Real-time Telemetry. Virtual Channel 1 for Playback Telemetry. Virtual Channel 3 for Payload scientific data dump

8 Environment Interface Requirements

The SPL shall comply with the environmental requirements defined in the following sections as well as the detailed environmental specifications, levels, test margins, and durations provided in [AD1]. Details will also be specified in the Science Payload to Spacecraft Interface Control Document.

8.1 Sine Vibration

The SPL shall be designed to withstand the sine vibration loads as defined in the following table without degradation

Table 8.1-1 Sine vibration test levels and durations (all axes)

Hz	Qualification	Proto-flight	Acceptance
5~25	Max shaker capability	Max shaker capability	Max shaker capability
25~100	26.25g	26.25g	21g
Sweep Rate	2 Oct/min	4 Oct/min	4 Oct/min
Level	x1.25	x1.25	x1

8.2 Random Vibration

The SPL shall be designed to withstand the random vibration loads as defined in the following table without degradation.

Table 8.2-1 Random Vibration Test Levels for Component Mass Over 2kg

Component Mass > 2 kg				
Frequency Range (Hz)	Qualification / Protoflight		Acceptance	
	Out of plane	In plane	Out of plane	In plane
20 – 100	+3 dB/oct	+3 dB/oct	+3 dB/oct	+3 dB/oct
100 – 600	0.2 g ² /Hz	0.1 g ² /Hz	0.1 g ² /Hz	0.05 g ² /Hz
600 – 2000	-6 dB/oct	-6 dB/oct	-6 dB/oct	-6 dB/oct
Test Duration (per axis)	2 mins / 1 min	2 mins / 1 min	1 min	1 min
RMS (g)	13.92	9.84	9.84	6.92

8.3 Shock

The SPL shall be designed to withstand the shock load depending on the locations chosen. Each shock zone is assigned to a shock level and is shown in the following figure. Whereas Position 1 is located on the upper side panel, Position 2 is on the lower side panel.

	Qualification	Proto-flight	Acceptance
Level	+3 dB	+3 dB	+0 dB
Sets	2 sets/axis	1 set/axis	1 set/axis

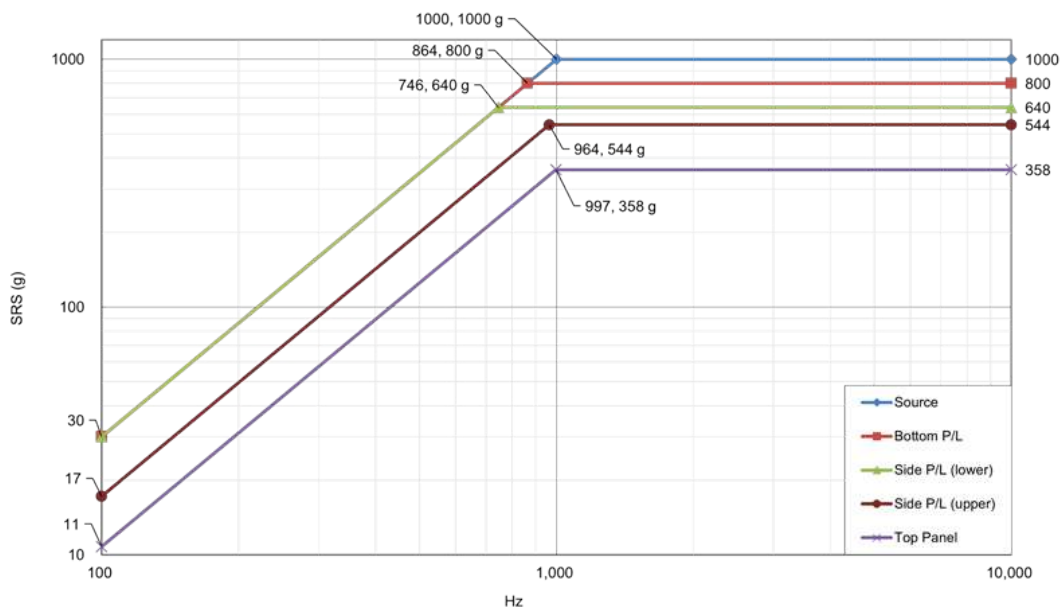

Figure 8.3-1 Shock prediction level in each zone

8.4 Thermal Test(s)

The SPL shall conduct thermal vacuum testing to demonstrate their thermal capability.

Table 8.4-1 Thermal Vacuum Test Requirements

Condition	Qualification	Protoflight	Acceptance	
Temperature	(OP/NOP) ± 10°C	(OP/NOP) ± 5°C	(OP/NOP) ± 5°C	(OP/NOP)
Pressure	≤ 5e-5 mbar			
Number of cycles	≥ 8	≥ 8	≥ 4	≥ 8
Dwell duration	≥ 2 hours	≥ 2 hours	≥ 2 hours	≥ 2 hours

	FORMOSAT-9B Science Payload to Spacecraft Interface Requirement Document	FS9B-IRD-XXXX
		01
		2026/05/26
		27 OF 35

9 Requirements Verification

The requirements shall be in accordance with the methods indicated in the Requirement Verification Matrix. The methods selected for verification are described below.

Inspection

Verification by inspection is a process which may be used in lieu of or in conjunction with testing to verify design features. Inspection is the process of physically measuring, examining or comparing an article to the design drawings, schematics, or other records to assure requirements compliance. This method also includes the validation of records to ascertain that correct parts, materials and processes were used.

Demonstration

Demonstration shall be the determination of properties and performance of an item involving proof-by-doing such as service and access, transportability and human engineering.

Analysis

Verification by analysis is a process used in lieu of or in addition to testing to verify compliance to specification requirements. The selected techniques may include systems engineering analysis, statistics and qualitative analysis, computer and hardware simulations, and analog modeling. Analytical techniques may be used in lieu of tests for such things as reliability assessment, life, storage, failure analysis, safety, interchangeability, and other performance requirements which are difficult or impractical to test. Analysis associated with qualification by similarity is included in this method.

Test

Test shall be the determination of properties and performance of an item by mechanical, electrical and environmental functional measurements. Tests shall be classified as follows:

Performance Testing: Comprehensive verification that the Bus meets the performance characteristics defined in Section 3 and identified in the Verification Cross Reference Matrix under both nominal conditions and environments.

Environmental Testing: Any testing performed under conditions other than the ambient environment.

Acceptance Testing: The environmental, electrical, mechanical, and other tests which all items intended for flight must pass. The tests are designed to verify proper workmanship and to demonstrate that the Bus will operate as specified when subjected to the expected worst-case environmental conditions.

Protoflight Testing: The environmental, electrical, mechanical, and other tests required to verify that the Bus components will comply with design and performance requirements under anticipated operational regimes and environments. The environment of protoflight tests shall be harsher than the predicted operational environment, but below the design safety factor level so that the components need not be refurbished prior to flight. Exposure time is based on the use cycle and/or type of flight item. When several units of the same component are

	FORMOSAT-9B Science Payload to Spacecraft Interface Requirement Document	FS9B-IRD-XXXX
		01
		2026/05/26
		28 OF 35

manufactured, only one shall be protoflight tested. Protoflight testing applies only to those component types identified below.

- i New designs
- ii. Modified designs
- iii. Existing designs with qualification levels that do not meet FORMOSAT-9B requirements

9.1 Requirements Verification Cross-Reference Matrix (VCRM)

Science Payload IRD shall be flown down to Science Payload ICD (Interface Control Document) during contract implementation. The contractor shall provide the flow down traceability table. VCRM of the Science Payload ICD shall be provided by the contractor. Appendix-B contains a sample format for the "VCRM - SPL ICD".

 TASA 國家太空中心 Taiwan Space Agency	FORMOSAT-9B Science Payload to Spacecraft Interface Requirement Document	FS9B-IRD-XXXX
		01
		2026/05/26
		29 OF 35

Appendix A. Acronym

Acronym	
ACS	Attitude Control System
ADC	Analog to Digital Converter
AIT	Assembly, Integration and Test
AOCS	Attitude and Orbit Control Subsystem
APA	Attitude Pointing Accuracy
APK	Attitude Pointing Knowledge
ASR	Acquisition Schedule Report
BER	Bit Error Rate
CA	Contract Award
C&DH	Command and Data Handling
CAD	Command Allocation Document
CCB	Configuration Control Board
CDR	Critical Design Review
CLIN	Contract Line Item Numbers
CMD/TLM	Command/Telemetry
COTS	Commercial Off-The-Shelf
CPU	Central Processing Unit
CPCU	Central Processing and Control Unit
CT	Clean Tent
CSC	Computer Software Component ,
CSCI	Computer Software Configuration Item
CSU	Computer Software Unit
CG	Center of Gravity
DBF	Digital Beam Forming
DC	Duty Cycle
DCM	DC Module
DEM	Deployment Mechanism
DL	Downlink
EBB	Elegant Bread Board

	FORMOSAT-9B Science Payload to Spacecraft Interface Requirement Document	FS9B-IRD-XXXX
		01
		2026/05/26
		30 OF 35

Acronym	
EDAC	Error Detection and Correction
EDM	Engineering Development Model
EGSE	Electrical Ground Support Equipment
EIRP	Equivalent Isotropically Radiated Power
EM	Engineering Model
EMC	Electro Magnetic Compatibility
EOL	End Of Life
EPS	Electrical Power Subsystem
EQM	Engineering Qualification Model
FCU	Flow control unit
FDF	Flight Dynamic Facility
FDIR	Failure Detection, Isolation and Recovery
FM	Flight Model
FMECA	Failure Modes, Effects and Criticality Analysis
FOH	Flight Operation Handbook
FOV	Field of View
FPGA	Field Programmable Gate Array
FR	Final Review
FSW	Flight Software
GCN	Ground Communication Network
GNSS	Global Navigation Satellite System
GNSSR	Receiver for Global Navigation Satellite System
GPSR	Global Positioning System Receiver
GUI	Graphic User Interface
HPC	High Priority Command
HW	Hardware
ICD	Interface Control Document
ICWG	Interface Control Working Group
IDR	Interface Design Review
IF	Interface
IOC	Input/Output Control

	FORMOSAT-9B Science Payload to Spacecraft Interface Requirement Document	FS9B-IRD-XXXX
		01
		2026/05/26
		31 OF 35

Acronym	
IP	Intellectual Property
IPC	The Institute for Interconnecting and Packaging Electronic Circuits
IPS	Image Processing System
IRD	Interface Requirements Document
IRU	Inertial Reference Unit
ISO	International Organization for Standardization
ITAR	International Traffic in Arms Regulations, ITAR
ITR	Integration and Test Readiness Review
ITU	International Telecommunication Union
LCL	Latching Current Limiter
LOS	Line of Sight
LRR	Launch Readiness Review
LV	launch vehicle
MCC	Mission Control Center
MDR	Mission Definition Review
MEMS	Microelectromechanical Systems
MEOP	Maximum expected operating pressure
MGSE	Mechanical Ground Support Equipment
MIL	Mission Timeline
MIPS	Mega (Million) Instructions Per Second
MOWG	Mission Operations Working Group
ML	Mission Life
MLI	Multi Layer Insulation
MO	Mission Orbit
MOI	Mass of Inertia
MOC	Mission Operation Center
MOP	Mission Operation Plan
MRAM	Magnetoresistive Random Access Memory
MTQ	Magnetic Torquer
NCC	National Communications Commission
OAP	Orbital Average Power

This document contains proprietary and controlled information of Taiwan Space Agency (TASA) in Taiwan and shall not be duplicated in whole or in part for any purpose without permission from TASA.

 TASA 國家太空中心 Taiwan Space Agency	FORMOSAT-9B Science Payload to Spacecraft Interface Requirement Document	FS9B-IRD-XXXX
		01
		2026/05/26
		32 OF 35

Acronym	
OASPL	Overall Sound Pressure Level
OBC	On Board Computer
OCT	Optic Communication Terminal
ORR	Operation Readiness Review
OTP	Overall Test Plan
PA	Power Amplifier
PAPP	Product Assurance Program Plan
PCM	Phase Change Material
PCU	Power Control Unit
PDHTS	Payload Data Handling and Transmission System
PDR	Preliminary Design Review
PDTS	Payload Data Transmission System
PFD	Power Flux Density
PM	Processor Module
PMP	Program Management Plan
POD	Precision Orbit Determination
PPS	Pulse Per Second
PPU	Power Processing Unit
PSR	Pre-Shipment Review
PSS	Planning and Scheduling Subsystem
P/L	Payload
RCS	Reaction Control Subsystem
RF	Radio Frequency
RFI	Radio Frequency Interference
RFP	Request For Proposal
RHCP	Right Hand Circular Polarization
RR	Radio Regulation
RTS	Remote Terminal Station
RW	Reaction Wheel
Rx	Receiver
SAPS	Solar Array Power Simulator

 TASA 國家太空中心 Taiwan Space Agency	FORMOSAT-9B Science Payload to Spacecraft Interface Requirement Document	FS9B-IRD-XXXX
		01
		2026/05/26
		33 OF 35

Acronym	
SAR	Synthetic Aperture Radar
SAT	System Acceptance Test
SCOE	System or Special Check-Out Equipment
SDC	Science Data Center
SDR	System Design Review
SEU	Single-Event Upset
SID	System Interface Document
SIT	System Integration Test
SM	Structural Model
SMS	Structure and Mechanism Subsystem
SOCC	Satellite Operation and Control Center
SOH	Status of Health
SPL	Sound Pressure Level
SP/L	Science Payload
SRR	System Requirements Review
SRS	Software Requirement Specification
SS	Sun Sensor
SSO	Sun Synchronous Orbit
SSR	Solid State Recorder
STC	Satellite Test Controller
SW	Software
TAA	Technical Assistance Agreement
TAD	Telemetry Allocation Document
TBD	To Be Defined
TBR	To Be Revised
TCS	Thermal Control Subsystem
TDM	Technology Demonstration Model
TMTC	Telemetry/Telecommand
TRM	Transmitter/Receiver Module
TRR	Test Readiness Review
TA	Technical Audit

	FORMOSAT-9B Science Payload to Spacecraft Interface Requirement Document	FS9B-IRD-XXXX
		01
		2026/05/26
		34 OF 35

Acronym	
TT&C	Telemetry, Tracking and Command
Tx	Transmitter
UART	Universal Asynchronous Receiver/Transmitter
UL	Uplink
VCRM	Requirements Verification Cross-Reference Matrix
V&V	Verification & Validation
WBS	Work Breakdown Structure
WSD	Work Start Date
XAS	X-Band Antenna Station
XBA	X-band Antenna
XDS	X-band Downlink Subsystem
XPAA	X-band Phased Array Antenna
XPATx	X-band Phased Array Transmitter
WDT	Watch Dog Timer

 TASA 國家太空中心 <small>Taiwan Space Agency</small>	FORMOSAT-9B Science Payload to Spacecraft Interface Requirement Document	FS9B-IRD-XXXX
		01
		2026/05/26
		35 OF 35

Appendix B. Sample Science Payload ICD Verification Cross- Reference Matrix (VCRM)

Req. Id	Requirement text	Verif. Meth.	Verif. Occ.	Verif. Doc.	Test Procedure	Status
SICD-0100	<i>Science payload shall be grounded in accordance with the spacecraft bus grounding scheme as specified in AD2.</i>	ii, tt	CDR	<i>FS9A-RPT-000* Section * Figure *, Page *</i>	<i>FS9A-PRC-000*</i>	ii-Close tt-Open
SICD-0110	<i>The science payload shall consume less than 15W orbit average power.</i>	ii, aa, tt	CDR	<i>FS9A-RPT-000* Section * Figure *, Page *</i>	<i>FS9A-PRC-000*</i>	aa-Close